

ITEM NO.	DWG/PART No.	MATERIAL	DESCRIPTION	QTY.
1		BS EN 12588	CODE 3 LEAD SHEET, 1.32mm THK	5
2		PE610g-FR-PVC, BS 7837-1996, YELLOW	PLASTIC COVER, OUTER	2
3	"DTP SUPPLIES" 2A/6/2C	BRASS	6 GROMMET EYELET AND WASHER	10
4			CALDER LABEL	1

FOR ITEM 3, SEE TABLE FOR QUANTITIES

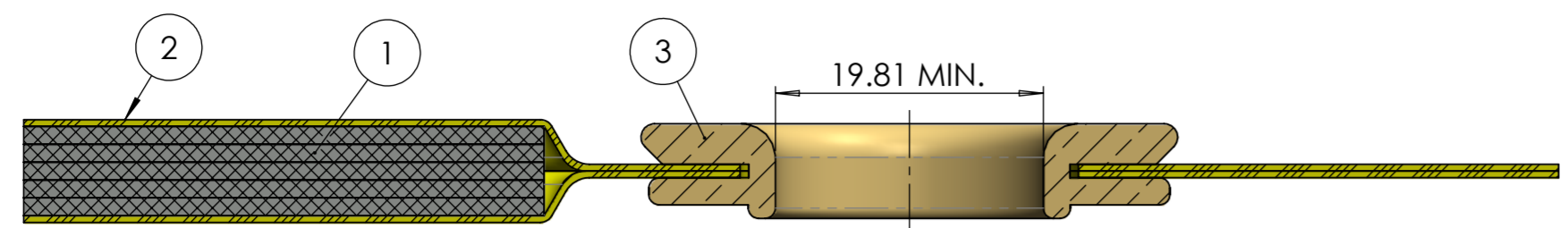

SECTION A-A
SCALE 2:1

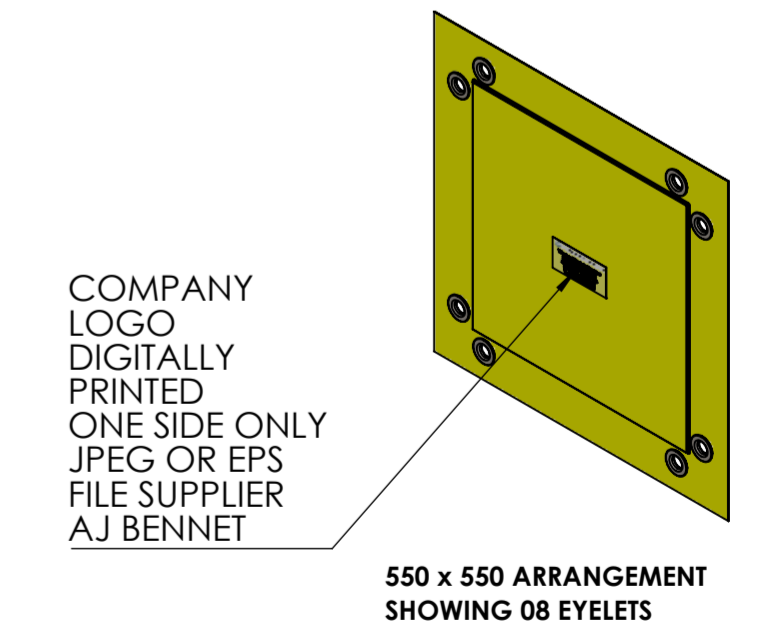
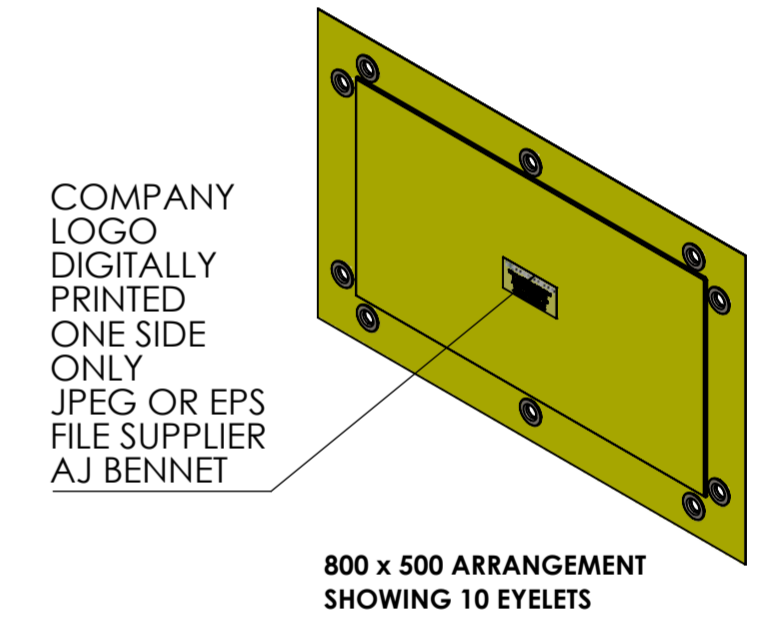
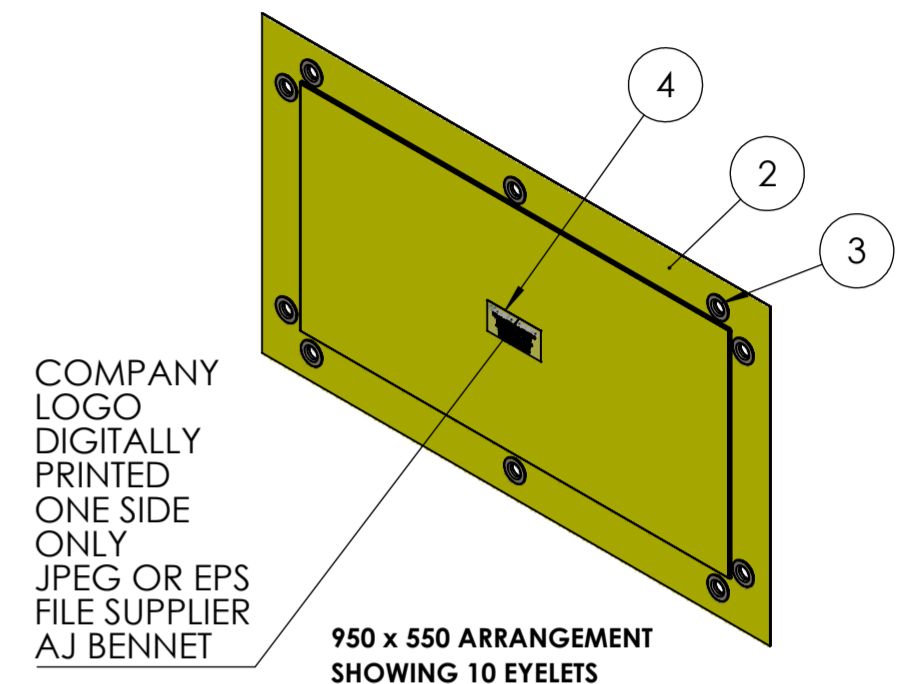
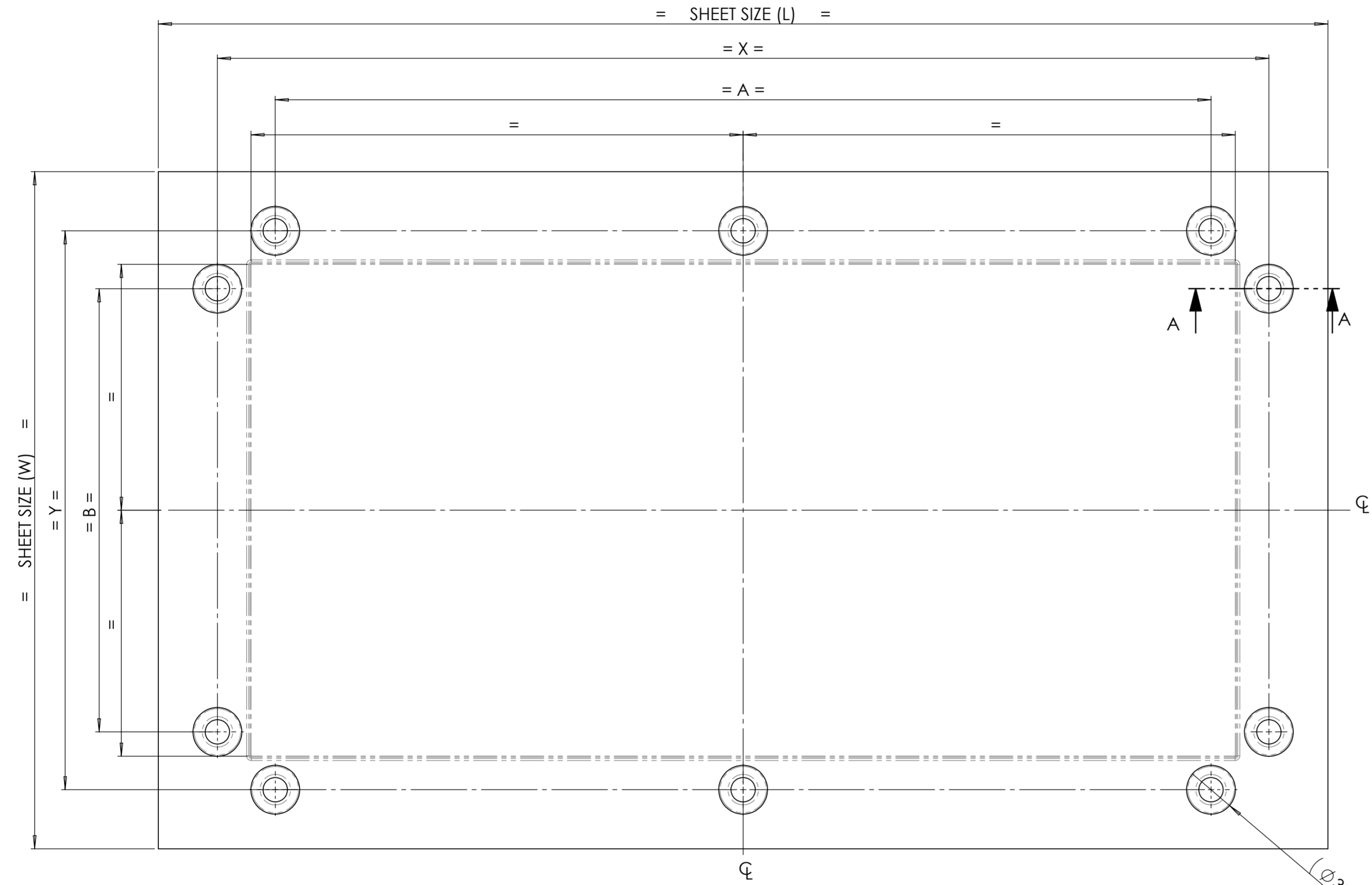

SHEET SIZE (L x W)	LEAD SIZE	A	B	X	Y	NO. OF EYELETS (ITEM 3)	APPROX. WEIGHT (kg)
950 x 550	800 x 400	760	360	854	454	10	25
800 x 500	650 x 350	610	310	704	404	10	18
550 x 550	400 x 400	360	360	454	454	08	13

- NOTES:**
- TOLERANCE ON LEAD THICKNESS: ±5%
 - TOLERANCE ON LEAD CUT EDGES: ±2mm
 - LEAD EDGES MUST BE CUT SQUARE
 - TOLERANCE FOR LENGTHS A, B, X & Y: ±3mm
 - TOLERANCE FOR PLASTIC SHEET SIZE: -0mm +5mm
 - SWL: 100kg PER EYELET

REV.	DESCRIPTION	APPROVED	DATE
07	DRAWING MOVED TO NEW DRAWING BORDER	JBL	30/10/2025
06	OUTER SHEET DIMS INCREASED BY 50mm. LEAD SHEET REVISED TO CODE 3	JBL	03/03/2020
05	DIM 'X' & 'Y' ADDED. ITEM 3 Pt. No. UPDATED. NOTE 5 TOL. WAS ±3	DP	05/03/2019
04	SIZE 650x350 WAS 610x310. DIM 'A' & DIM 'C'	RS	09/11/2017
03	GROMMET EYELET & WASHER SIZE UPDATED, WEIGHT ADDED TO TABLE	RT	30/11/2015
02	LAYOUT UPDATED, SHEETS 2 & 3 REMOVED	RT	20/11/2015
01	DIMS UPDATED, ITEM 3 REVISED, SHEETS 2 & 3 ADDED	JBL	17/11/2015

THIS DOCUMENT INCLUDING THE COPYRIGHT THEREIN IS THE EXCLUSIVE PROPERTY OF CALDER INDUSTRIAL MATERIALS, CHESTER UK. IT MAY ONLY BE USED FOR THE PURPOSE FOR WHICH IT WAS ISSUED. IT MAY NOT BE DUPLICATED IN ANY WAY, NOR TRANSMITTED TO ANY THIRD PARTY WITHOUT THE EXPRESS PERMISSION OF CALDER INDUSTRIAL MATERIALS.

CALDER
CALDER INDUSTRIAL MATERIALS LTD
Jupiter Drive, Chester West Employment Park
Chester, CH1 4EX. Tel. 01244 390093

GENERAL TOLERANCES UNLESS OTHERWISE STATED

MACHINING
ISO 2768-mK

FABRICATION & LEAD LENGTH
ISO 2768-ck

CASTING & ROLLED LEAD THICKNESS
± 5%

DRAWN	DP
DATE	30/09/15
CHECKED	JD
APPROVED	JBL
PROJECT	CIM
SCALE	1:3

TITLE				STANDARD LEAD BLANKET			
MATERIAL				WEIGHT 25.00 Kg FINISH NATURAL			
DRAWING No.		SHEET		REV			
CSPM0037		1 / 1		07			